

# SHURE®

LEGENDARY  
PERFORMANCE™

## PGXD Wireless System

# Shure PGXD Wireless

PGXD sans fil de Shure

Sistema inalámbrico Shure PGXD

Shure PGXD Sem Fio



©2010 Shure Incorporated  
27B14513 (Rev. 2)  
Printed in U.S.A.



CE



# SHURE®

## PGXD Wireless

### Quick Start Guide

Mise en service rapide  
Schnelles Einrichten

Preparación Rápida  
Installazione rapida

Montagem Rápida  
クイックセットアップ

快速设置指南  
빠른 설정

Быстрая настройка  
الأعداد السريع

1

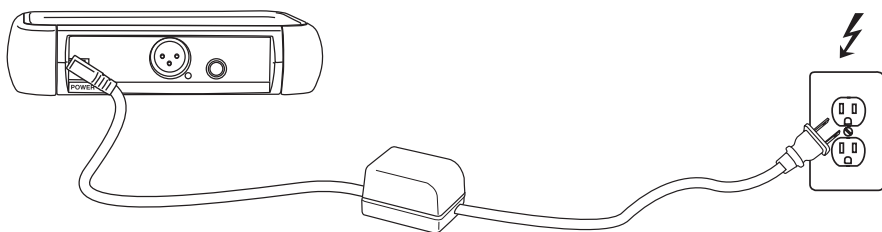

connect receiver power cable

2

MIC OUT

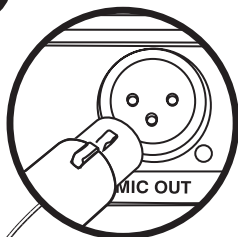

INSTRUMENT OUT

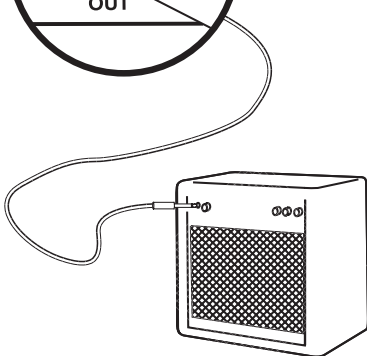
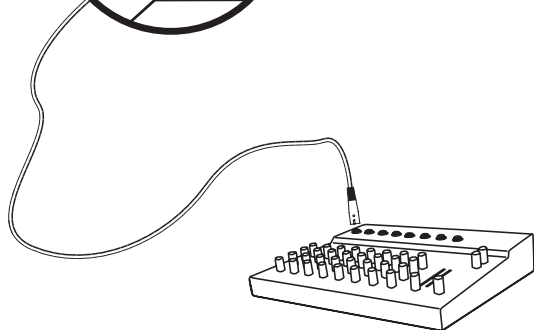
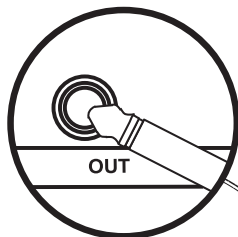

connect mixer or amplifier

3

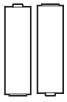

2 x AA

add transmitter batteries

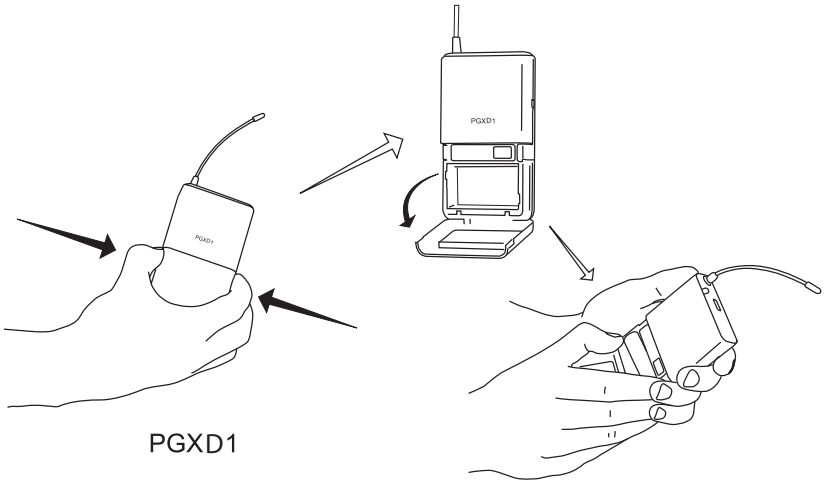

PGXD1

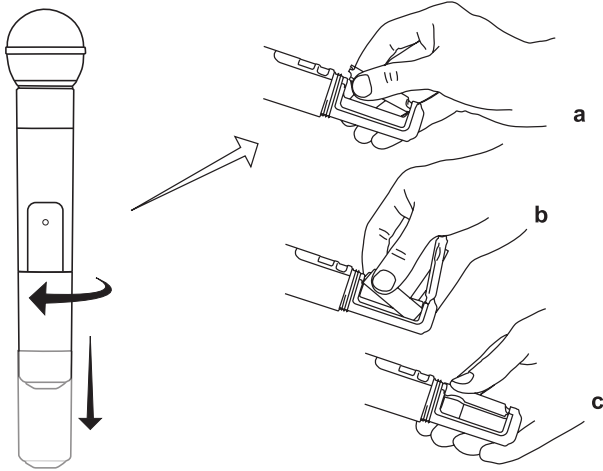

PGXD2

4

power

scan for a clear channel and power up

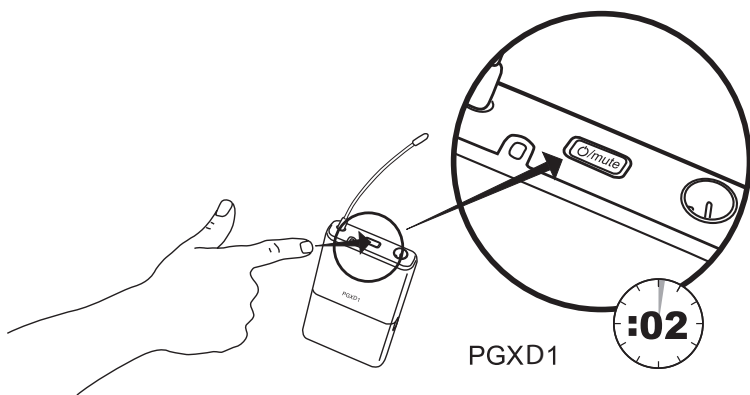
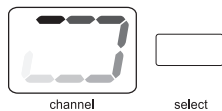
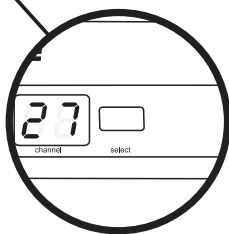
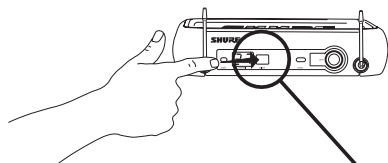

PGXD1

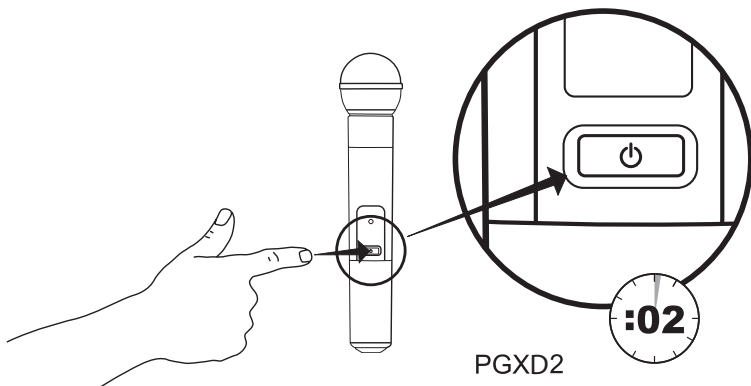

PGXD2



5



# Sync

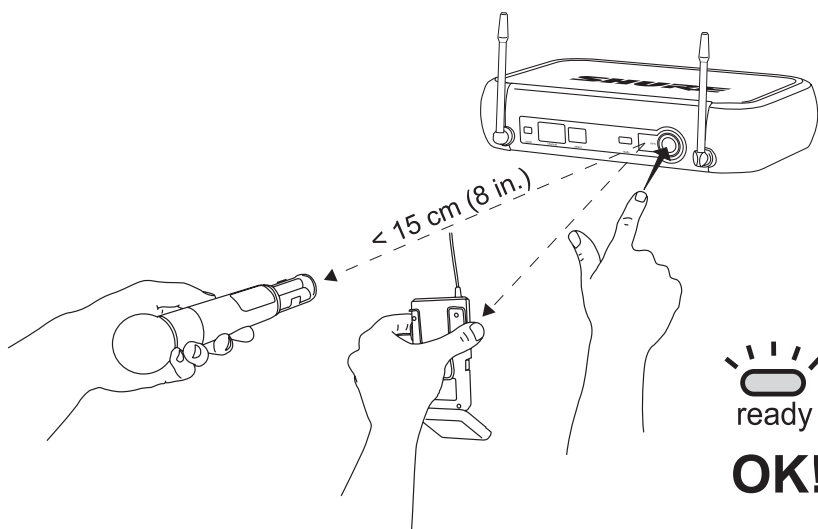
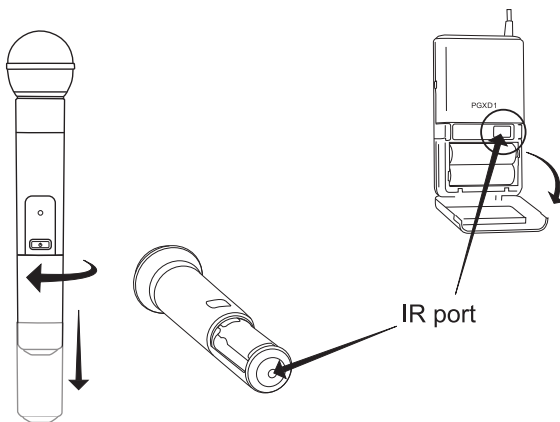

# PGXD

## System Components

### PGX Digital Wireless Systems

Offering uniquely tailored wireless solutions for vocalists, guitarists, and presenters, PGX-Digital combines the trusted legacy of Shure wired microphones with state-of-the-art, 24-bit digital wireless technology to deliver strong, clean RF performance. The result is wireless audio that sounds like wired, rock-steady RF signal even at extended distances, and plug-and-play setup and operation.

- Professional quality 24-bit digital audio
- Digital RF technology for rock-solid performance
- Wide variety of rugged and dependable Shure microphones
- One-touch setup and operation
- Up to 10 hours of battery life (9 hours, PGXD2)
- Up to 200 foot range (line-of-sight)
- 900 MHz operation—free from white spaces or DTV interference

#### All systems include

- PGXD4 receiver
- 2 AA alkaline batteries
- Power supply
- User guide

#### Vocalist systems include

- PGXD2 handheld transmitter
- Microphone head (choice of PG58, SM58®, SM86, Beta 58A® or Beta 87A\*)
- Microphone clip
- \* Available only in select markets

#### Lavalier, Headworn, and Instrument systems include

- PGXD1 bodypack transmitter
- Microphone (choice of WL93, WL185, PG30 or Beta 98H/C)

#### Guitar systems include

- PGXD1 bodypack transmitter
- 1/4" to mini 4-pin guitar cable (WA302)

### Receiver Controls and Connectors

#### PGXD4

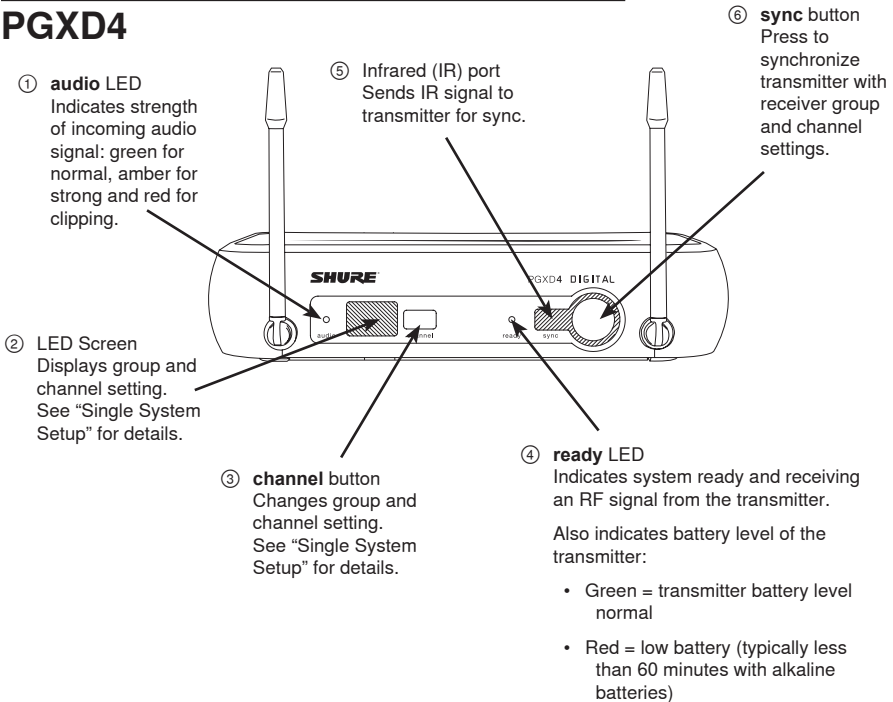

**Note:** with NiMH rechargeable batteries, when the indicator turns red there will be little to no remaining life.

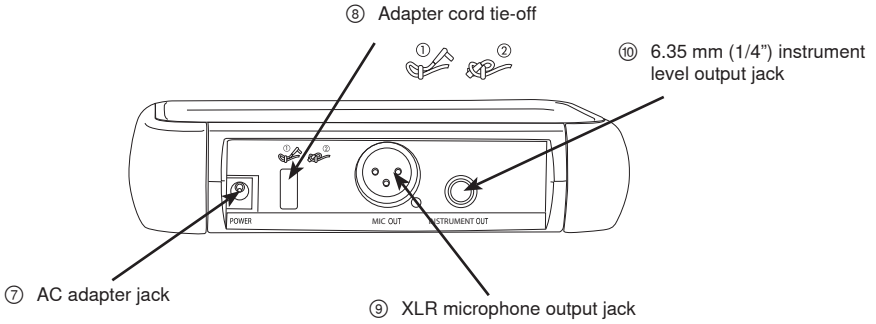

## Transmitter Controls and Connectors PGXD2

- ① Indicator LED  
Displays battery level, mute, and IR transmission status (see table).
- ② Power / Mute Switch  
Press to mute or unmute. Press and hold to power on or off.
- ③ Infrared (IR) port  
Receives infrared beam to synchronize frequencies.  
**When using multiple systems, only one transmitter IR port should be exposed at a time.**
- ④ 4-Pin Microphone Input Jack
- ⑤ Audio Gain Adjustment

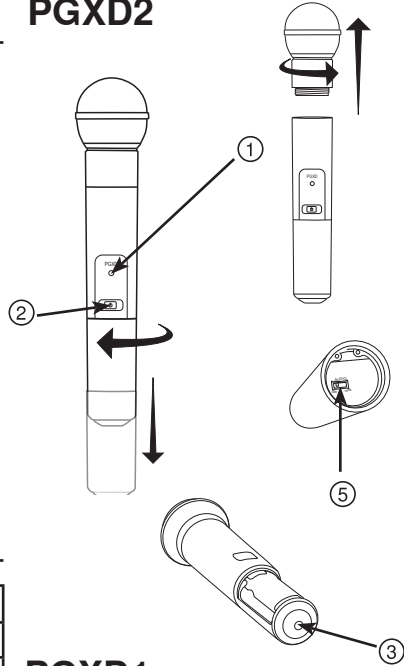

## Transmitter Indicator LED

LED Indicator	Status
Green	Ready
Flashing green	Controls locked
Amber	Mute on
Solid red	Battery power low
Flashing red	Batteries dead (change batteries to power on transmitter)
Rapidly flashing red	IR transmission in process
Flashing amber and red	Battery power low and mute on

## PGXD1

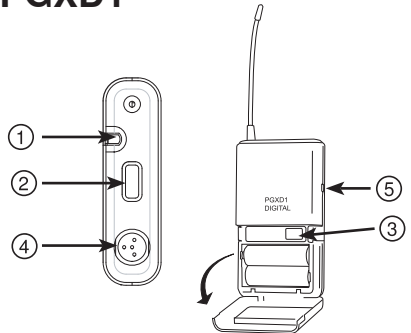

## Batteries

- A fresh set of alkaline batteries lasts up to 10 hours (9 hours, PGXD2).
- The transmitter LED and the receiver **ready** LED glow red to indicate low battery (typically less than 60 minutes remaining).
- NiMH rechargeable batteries may be used. However, the low battery indicator functions differently. When it turns red, there may be little to no remaining life.
- When the LED flashes red, the batteries must be replaced to power on the transmitter.

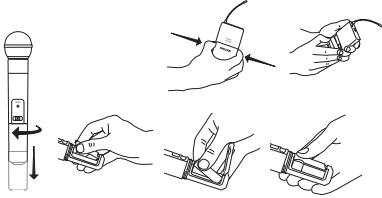

## Adjusting Gain

For best audio quality, set transmitter gain so the **audio** LED on the receiver flickers green and amber during the performance. Decrease gain if the signal clips (LED turns red).

**Note:** The amber LED may appear to be red when viewed at an angle. For best results, monitor the LED from directly in front.

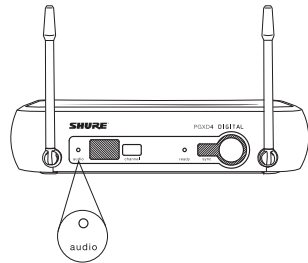

## Bodypack Transmitter

The bodypack has 26 dB of audio gain adjustment.

- Increase gain (clockwise +) for microphones
- Decrease gain (counterclockwise -) for guitars or high-output instruments

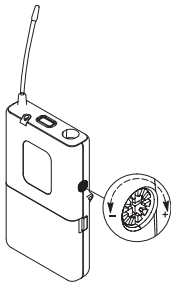

## Wearing the Bodypack Transmitter

Clip the transmitter to a belt or slide a guitar strap through the transmitter clip as shown.

For best results, slide the transmitter until the belt is pressed against the base of the clip.

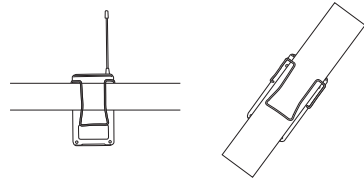

## Handheld Transmitter

Access the gain switch by unscrewing the head of the microphone.

Use the tip of a pen or a small screwdriver to move the switch.

- **0dB:** For quiet to normal vocal performance.
- **-10dB:** Use only if audio is distorted due to high vocal levels.

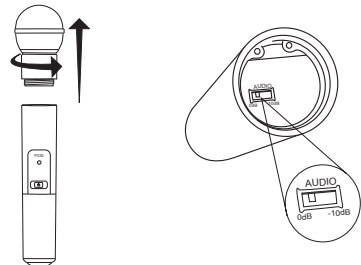

# Single System Setup

## 1 Scan

Use the scan feature on the receiver to find a clear channel.

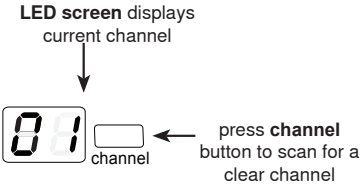

system scans for the channel with the least interference

## 2 Synchronize

Synchronize the transmitter to the receiver by aligning the infrared (IR) ports and pressing the **sync** button. **Make sure the IR ports are closely aligned.**

After a successful sync, the transmitter LED momentarily flashes red and the receiver **ready** light illuminates.

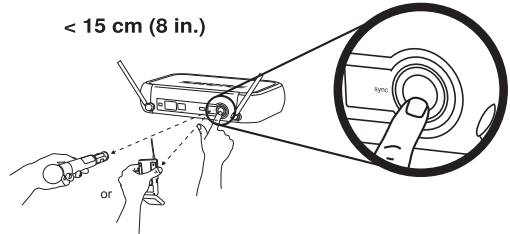

**NOTE:** This wireless system may be affected by RF interference when used in proximity to other wireless devices such as cordless phones, baby monitors, and two-way radios. For best results, use the scan and sync feature before each use or if you experience problems.

# Multiple System Setup

Use the following steps to ensure the best performance when installing multiple wireless systems at the same location.

1. Turn all receivers **on** and all transmitters **off**.

Note: Turn on any other digital equipment that could cause interference during the performance so it will be detected during the frequency scans in the following steps.

2. Make sure the group number is the same for all receivers (see Manual Group Selection).
  3. Perform a scan using the first receiver.
  4. Turn on the first transmitter and sync it to the receiver.
  5. Repeat for each system.
- **Important:** After syncing each transmitter, leave it on so that scans from the other receivers will not select that channel.
  - Be sure only one transmitter IR port is exposed when synchronizing each system.

## Compatible Frequencies

When operating multiple systems simultaneously, choose one group from the following table and set all systems to different channels within that group.

Number of Systems	Group (by band)		
	X8	X8A (Australia)	X8B (Brazil)
2	3 to 9	3 to 9	3 to 9
3	3 to 9	3 to 9	3 to 9
4	3 to 9	--	3 to 9
5	7 to 9	--	--

## Manual Channel and Group Selection (receiver only)

---

Using the receiver to scan for a channel is the best way to find the best frequency for your system. However, for multiple system setup, you may need to manually set the group number.

1. Press and hold the **channel** button.
2. Hold the button until the channel or group display begins flashing.
3. Release and press the button again to advance the setting.  
At the desired channel or group number, wait for the flashing to stop. This activates the new setting.
4. Transfer the new frequency setting to the transmitter using the automatic sync function.

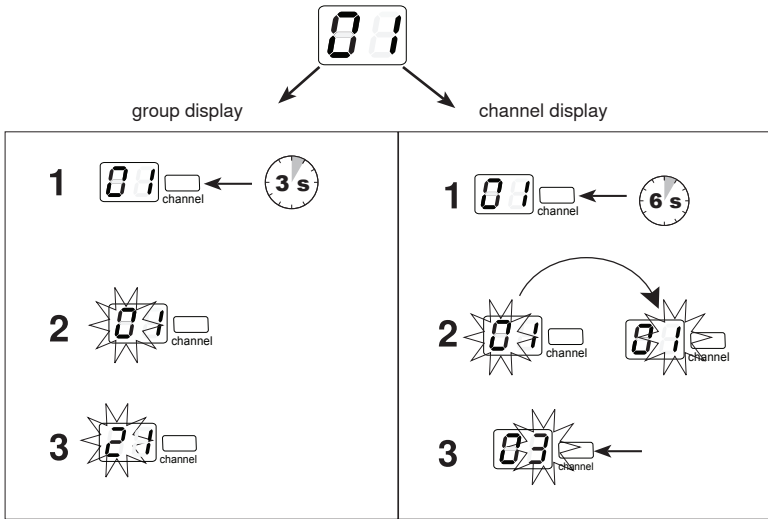

## Locking and Unlocking Controls

---

Locking the system controls prevents accidental muting or channel adjustment during performances.

### Transmitter

**To lock the controls:** With the transmitter **off**, hold the **power** button down until the green LED flashes (~5 seconds)

**To unlock the controls:** With the transmitter **on**, hold the **power** button down until the green LED flashes (~5 seconds)

### Receiver

**To lock the channel:** Hold the **channel** button until the numbers flash (~10 seconds)

**To unlock the channel:** Hold the **channel** button until the numbers flash (~5 seconds)

# Troubleshooting

Issue	Indicator Status	Solution
<b>No sound or faint sound</b>	Receiver <b>ready</b> LED on	Verify all sound system connections
	Receiver <b>ready</b> LED off	<ul style="list-style-type: none"> <li>• Turn on transmitter</li> <li>• Make sure the batteries are installed correctly</li> <li>• Perform automatic transmitter setup</li> <li>• Insert fresh batteries</li> </ul>
	Receiver LED screen off	Make sure AC adapter is securely plugged into electrical outlet
	Transmitter indicator LED flashing red	Replace transmitter batteries.
	LED screen shows dash and value	Error code displayed. Contact your Shure reseller for assistance.
	Transmitter LED flashes red for 7 seconds after attempting to sync	Transmitter and receiver incompatible. Contact your Shure reseller for assistance.
<b>Noise bursts or audio dropouts</b>	N/A	<ul style="list-style-type: none"> <li>• Change receiver and transmitter to a different channel</li> <li>• Remove nearby sources of RF interference such as cordless or cell phones, computers, wireless routers, media players, digital signal processors, and security systems.</li> <li>• Replace transmitter batteries</li> <li>• If using multiple systems, change the frequency of one of the active systems</li> </ul>
<b>Distortion</b>	Audio LED on receiver indicates clipping (red)	Reduce transmitter gain
<b>Distortion increases gradually over time</b>	Transmitter power light glowing or flashing red	Replace transmitter batteries
<b>Sound level different from cabled guitar or microphone or when using different guitars</b>	N/A	Adjust transmitter gain as necessary
<b>Cannot turn transmitter on</b>	Transmitter LED slowly flashing red	Replace transmitter batteries
	Transmitter LED rapidly flashing red	Contact your Shure reseller for assistance.

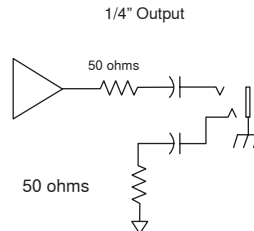
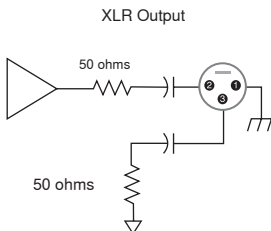

# SPECIFICATIONS

---

## Working Range (Line of Sight)

60 m (200 ft)

Note: Actual range depends on RF signal absorption, reflection and interference.

## RF Carrier Range

X8: 902–928 MHz

X8A: 915–928 MHz

X8B: 902–907.5 MHz, 915–928 MHz

Note: varies by region

## Audio Frequency Response

20–20000 Hz

Note: Dependent on microphone type

## Total Harmonic Distortion (Ref. 1 kHz, 6 dB below

input clip)

<0.02%, A-weighted, typical

## Dynamic Range

>108 dB, A-weighted

## Operating Temperature Range

-18°C (0°F)– +50°C (122°F)

Note: Battery characteristics may limit this range.

## Transmitter Audio Polarity

Positive pressure on microphone diaphragm (or positive voltage applied to tip of WA302 phone plug) produces positive voltage on pin 2 (with respect to pin 3 of low-impedance output) and the tip of the high impedance 1/4-inch output.

## PGXD1 Bodypack Transmitter

### Audio Input Level

+10 dBV maximum, at minimum gain setting

-16 dBV maximum, at maximum gain setting

### Gain Adjustment Range

26 dB

### Input Impedance

1 MΩ

### RF Output Power

10 mW

varies by region

### Pin Assignments

TA4M:

1: ground (cable shield)

2: + 5 V Bias

3: audio

4: Tied through active load to ground (On instrument adapter cable, pin 4 floats)

### Dimensions

108 mm x 64 mm x 19 mm (H x W x D)

### Weight

128 g (4.5 oz.)(without batteries)

### Housing

Molded polycarbonate case

### Power Requirements

2 "AA" size alkaline or rechargeable batteries

### Battery Life

up to 10 hours

## PGXD2 Handheld Transmitter

### Audio Input Level

+5 dBV maximum at -10 dB gain position

-5 dBV maximum at 0 dB gain position

### Gain Adjustment Range

10 dB

### RF Output Power

10 mW

varies by region

### Dimensions

254 mm X 51 mm dia. (10 X 2 in.)

### Weight

349 g (12.3 oz.) (without batteries)

### Housing

Molded PC/ABS handle and battery cup

### Power Requirements

2 "AA" size alkaline or rechargeable batteries

### Battery Life

up to 9 hours

## PGXD4 Wireless Receiver

### Dimensions

40 mm X 181 mm X 104 mm (H x W x D)

### Weight

289 g (10.2 oz.)

### Housing

ABS

### Sensitivity

-102 dBm @ 10<sup>-5</sup> BER

### Power Requirements

12–18 V DC @ 150 mA, supplied by external power supply (tip positive)

### Audio LED

Red: 2 dB below clip

Amber: 12 dB below clip

Green: 50 dB below clip

### Audio Output

### Configuration

Impedance balanced

### Audio Output Level (1 kHz tone)

XLR connector: -2.5 dBV (into 3 kΩ load)

6.35 mm (1/4") connector: +10 dBV (into 10 kΩ load)

### Impedance

XLR: 50 Ω

6.35 mm (1/4"): 50 Ω

### Pin Assignments

XLR: 1=ground, 2=hot, 3=cold

6.35 mm (1/4") TRS: Tip=audio, Ring=no audio, Sleeve=ground

# CERTIFICATION

---

## PGXD1, PGXD2, PGXD4

This Class B digital apparatus complies with Canadian ICES-003.

Cet appareil numérique de la classe B est conforme à la norme NMB-003 du Canada.

Certified by IC in Canada under RSS-210 and RSS-102. (IC: 616A-PGXD1, 616A-PGXD2, 616A-PGXD4).

## PGXD1, PGXD2

Certified under FCC Part 15. (FCC ID: DD4PGXD1, DD4PGXD2).

## PGXD4

Approved under the Declaration of Conformity (DoC) provision of FCC Part 15.

Operation of this device is subject to the following two conditions: (1) this device may not cause interference, and (2) this device must accept any interference, including interference that may cause undesired operation of the device.

## LICENSING INFORMATION

Licensing: A ministerial license to operate this equipment may be required in certain areas. Consult your national authority for possible requirements. Changes or modifications not expressly approved by Shure Incorporated could void your authority to operate the equipment. Licensing of Shure wireless microphone equipment is the user's responsibility, and licensability depends on the user's classification and application, and on the selected frequency. Shure strongly urges the user to contact the appropriate telecommunications authority concerning proper licensing, and before choosing and ordering frequencies.

## INFORMATION TO USER

This equipment has been tested and found to comply with the limits for a Class B digital device, pursuant to Part 15 of the FCC Rules. These limits are designed to provide reasonable protection against harmful interference in a residential installation. This equipment generates, uses and can radiate radio frequency energy and, if not installed and used in accordance with the instructions, may cause harmful interference to radio communications. However, there is no guarantee that interference will not occur in a particular installation. If this equipment does cause harmful interference to radio or television reception, which can be determined by turning the equipment off and on, the user is encouraged to try to correct the interference by one or more of the following measures:

- Relocate the receiving antenna.
- Increase the separation between the equipment and receiver.
- Connect the equipment into an outlet on a circuit different from that to which the receiver is connected.
- Consult the dealer.

**Note:** EMC conformance testing is based on the use of supplied and recommended cable types. The use of other cable types may degrade EMC performance.

**Changes or modifications not expressly approved by the manufacturer could void the user's authority to operate the equipment.**

